

Sedona kitchen

ALUMINUM ESPRESSO MAKER MOKA POT

USE AND CARE
KEEP THIS MANUAL FOR FUTURE REFERENCE



NOTE: Retain these guidelines as an integral part of the product; ensure accessibility throughout its lifespan. These instructions offer general guidance for the use and care of stove-top aluminum espresso makers.

Caution: This coffee maker necessitates a heat source for operation and generates internal pressure. **Non-adherence to the guidelines may result in burn risks or the coffee maker bursting.**

BEFORE FIRST USE:

- Thoroughly examine the Espresso Maker: Verify the presence and good condition of all parts & wash with mild dish soap and warm water.
- Make sure to eliminate all packaging or adhesives from the unit.
- For best taste and aroma, we suggest brewing at least 3 rounds of espresso (following steps in this manual) & discarding them (do not consume). This will prime your espresso maker.
- Prior to each use, confirm the espresso maker's integrity and the presence of all components. Inspect the valve (1), funnel (3), gasket (4), and filter plate (5) to ensure they are undamaged and correctly positioned, as illustrated in this manual.
- Prior to each use, ensure the safety valve remains clear of any obstructions.
- This appliance is not intended for individuals with reduced physical, sensory, or mental capabilities, including children. Keep it out of children's reach.
- Use the espresso maker only for its designated purpose. The product is solely intended for household use.
- Never operate the espresso maker without water in the boiler chamber (2).
- **CAUTION: Only use clean, filtered water in the boiler chamber (2); other liquids are not suitable. Never use milk or other liquids as this may cause the espresso maker to burst. Using anything other than water may be dangerous.**
- Use the espresso maker exclusively with ground coffee made for household use on stovetop espresso makers. Do not use other products (e.g., barley, cocoa, coffee extracts, tea, coffee beans, coffee for percolating filters, coffee made for other types of machines, etc). **CAUTION:** Never mix sugar or other additives with the espresso coffee. This can cause the machine to clog, malfunction and burst.
- **WARNING: Never leave the appliance unattended during operation.**
- Avoid contact with the hot surfaces of the espresso maker; utilize the handle (7) and knob (8). Use protective heat gear if necessary.
- Confirm proper closure of the espresso maker before use.
- Always ensure the steam jet is away from the user.
- When utilizing a gas heat source, ensure the flame does not extend beyond the boiler chamber's lower surface area. Make sure the handle never gets exposed to direct heat.
- For electric/ceramic glass plate use, maintain a medium setting; avoid the highest heat.
- During operation, keep the lid (9) of the espresso maker closed. You may sporadically open it to take a peek and see where it is in the process. Open it carefully, slowly, and using proper heat protection.
- Never attempt to use in an oven or microwave.
- Do not use the handle to open or close the espresso maker. This can cause the handle to get damaged or break.
- If malfunctions occur, IMMEDIATELY refrain from using the product. Do not expose a damaged or malfunctioning espresso maker to heat.
- Position the espresso maker on suitable surfaces after use, as it will remain hot for a while. Avoid placing it on flammable surfaces or ones susceptible to heat damage or melting.
- After each use, allow the espresso maker to cool before opening.
- NEVER tap the funnel (3) against other surfaces such as trash cans to remove the coffee, as it may damage or deform the funnel, compromising proper sealing. You can use a fork or spoon to scoop out.
- Routinely inspect the rubber gasket for signs of wear and tear; replace if necessary. Recommended at least once a year.

TIPS

Brewing Process:

- Use ground coffee for stovetop espresso makers, with an appropriate grind. Avoid overly finely ground coffee as coffee that is too fine may pass through the filter and into the coffee.
- Avoid compacting coffee into the funnel (3).
- Keep a close eye on the heat to avoid boiling dry or scorching the coffee grounds.
- Coffee will start filling the upper chamber (6) after a few minutes.
- You should keep the lid closed during operation, but can sporadically open it to take a peek and see where it is in the process. Open it carefully, slowly, and using proper heat protection.
- Once you observe coffee starts filling the upper chamber (6), adjust the heat to medium-low. Allow a moment for the brewing process to complete.
- Turn off the heat and/or remove from the stove when the upper chamber (6) is full.

- For best taste, use a small spoon to stir the coffee in the upper chamber before pouring.

Water Quality:

- Use only filtered, fresh, cold or room temperature water.
- Do not introduce milk or other liquids into the boiler chamber (2).

COFFEE PREPARATION STEPS

1. Pour cold water into the boiler chamber (2) up to the lower edge of the safety valve, as illustrated in Fig. A.
2. Place the funnel filter (3) into the boiler chamber (2) following the instructions in Fig. B.
3. Add ground coffee into the funnel filter (3), as shown in Fig. C. Do not tamper or press down. Ensure no coffee grounds are left on the boiler chamber's rim as this may compromise the seal.
4. Screw the upper chamber (6) onto the boiler chamber (2) securely, as demonstrated in Fig. D. Avoid excessive force. Do NOT strain the handle (7).
5. Position the espresso maker on the heat source, as depicted in Fig. E. Ensure that, in the case of an open flame, it does not extend beyond the bottom rim of the boiler chamber. For electric/ceramic glass plate use, refrain from using the highest heat. Always position the handles away from direct heat to avoid damage.
6. Remove the coffee maker from the heat source once the upper unit (6) is filled with coffee. See tips for best performance.

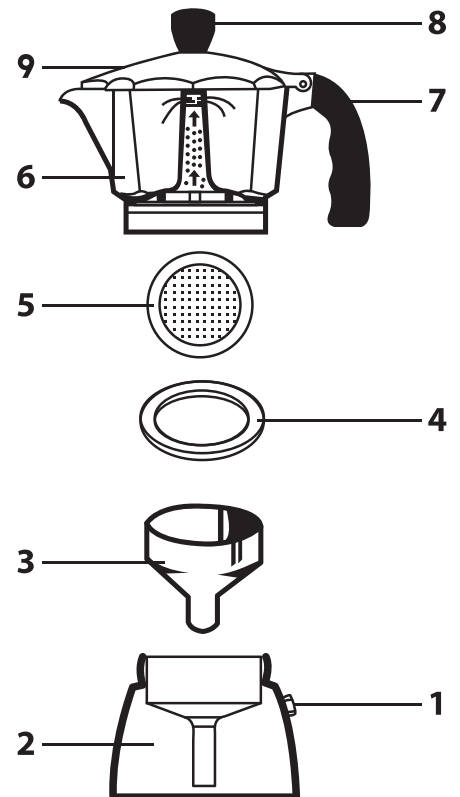
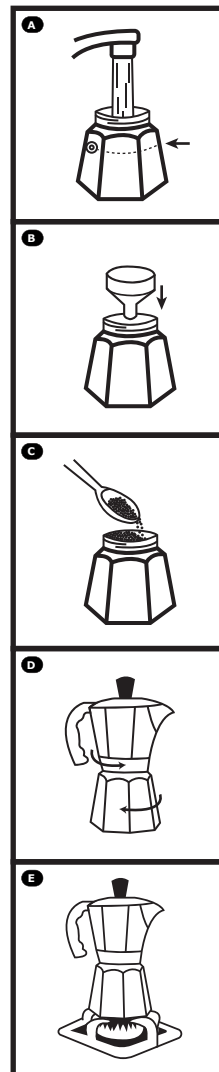

- 1- Safety Valve
- 2- Boiler Chamber
- 3- Funnel Filter
- 4- Gasket
- 5- Metal Filter
- 6- Upper Chamber
- 7- Handle
- 8- Knob
- 9- Lid



FAQ & TROUBLESHOOTING

1. Leaks or Drips:

Ensure the gasket is correctly positioned and in good condition. Verify that the coffee grounds in the filter funnel are not overflowing. Double-check the adequate tightening of the coffee maker.

2. Weak Coffee:

Confirm the use of properly ground espresso coffee intended for stovetop espresso makers. Explore different blends and roasted espresso options. Adjust the heat to medium-low for a more deliberate extraction.

3. The Coffee Maker Does Not Dispense:

Inspect the presence and proper arrangement of all components. Check gasket and valve.

4. The Safety Valve Vents Steam:

Confirm the use of properly ground espresso coffee intended for stovetop espresso makers. Verify that the coffee is not tampered or pressed tightly into the funnel. Check for an appropriate water level in the tank.

5. The Coffee Maker Fails to Dispense Coffee:

Reassess the tightness of the coffee maker. Investigate the coffee maker for any signs of leakage.

CLEANING AND MAINTENANCE

Before initiating cleaning and maintenance, allow the appliance to cool completely. It is advisable to regularly clean the coffee maker. After each use, wash with warm water without detergents or abrasive materials (the product is NOT dishwasher safe). Store the product completely dry, with all its parts separated and never closed. Periodically perform the decalcification procedure:

1. Add two teaspoons of citric acid or vinegar to the bottom boiler chamber.
2. Finish filling the boiler chamber with water up to the designated level.
3. Reassemble the product and run it using medium heat. Do not add coffee to the filter cup.
4. Discard the solution obtained.
5. Clean the coffee maker with fresh water and proceed to make coffee.

Regularly check that the holes of the filter plate (5) are not obstructed. If obstructed, use a brush with delicate bristles or a needle to clear the holes. Periodically inspect the internal components, and if wear or damage is detected, replace them solely with original spare parts suitable for the specific model. Replace the gasket (4) if worn; it is recommended to replace it at least once a year.

Store each part of the coffee maker thoroughly dry and without assembling or closing it.

DISPOSAL OF THE APPLIANCE

When the product reaches the end of its life, dispose of it in the regular waste. Depending on your local waste management, you may be able to recycle the purely aluminum parts such as the filter funnel, filter plate and bottom boiler chamber. Contact your local waste management for details.

WARRANTY

The product is covered by a limited 6-month warranty from the date of purchase, subject to the functional conditions outlined in this instruction leaflet. To claim warranty service, provide proof of purchase or an equivalent document indicating the dealer's identification data or the date of purchase. The warranty only covers manufacturing defects on the original product, by the original owner, under normal use and care. It only covers product purchased from an authorized retailer, and not second hand or unauthorized retailers.

Warranty does not cover: Replaced components (plate, funnel, gasket, and handle) for defects not of original origin. Failures and/or defects resulting from improper or non-compliant use with the instructions. Failures and/or defects arising from the use of non-compatible spare parts. Damages caused by impacts, falls, and limescale deposits.